

Outline Dimension Drawing For 1 Phase & 3 Phase Squirrel Cage TE FOOT(B3) Mounted Poultry Fan Induction Motors

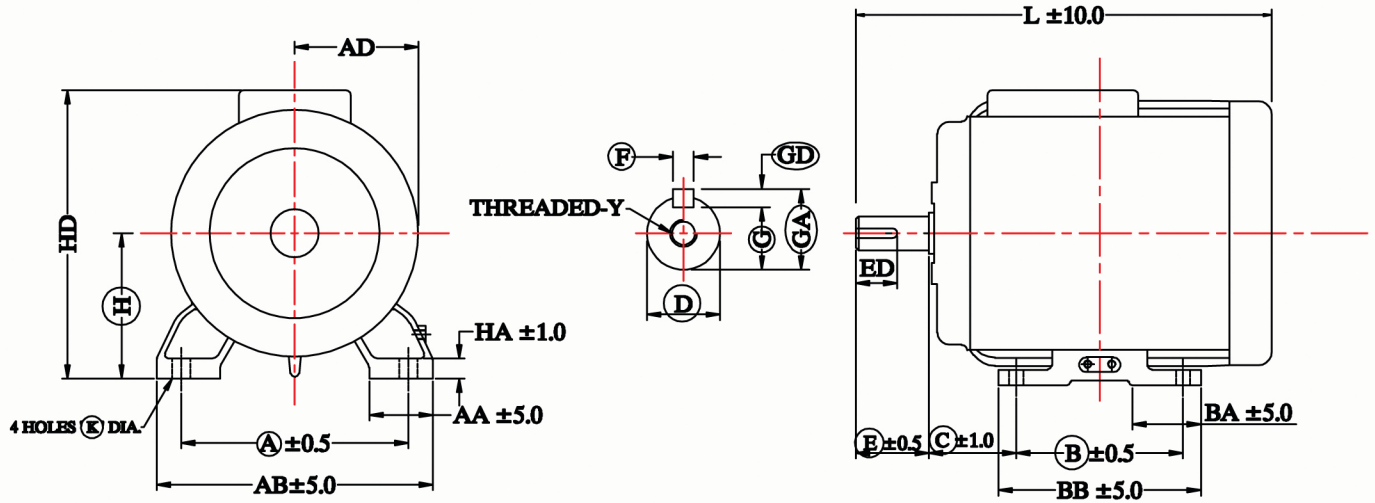

FRAME	A	B	C	H	AA	AB	BA	BB	K	D	E	ED	F	GD	G	GA	Y	AD	L	HA	HD
ND90L	140	125	56	89.5 90.0	41.0	170	30.0	145	10.0 10.5	24.009 23.996	50	36.0	8.000 7.910	7.000 6.910	20.0 19.8	27.0	M8x19	85.0	280.0	13	222

THESE DIMENSION MAY VARY BY 5mm DUE TO VARIATIONS IN CASTING
 RINGED DIMENSION MAY VARY BY ± 0.75 mm

	NAME	SIGN.	DATE	GENERAL TOLERANCE ON DIMENSIONS UNLESS OTHERWISE SPECIFIED						ALL DIMENSIONS IN MILLIMETRES UNLESS OTHERWISE SPECIFIED
DESIGNED	NMG			ABOVE	0.5	6.0	30	120	315	
DRAW	ABS			UPTO	6.0	30	120	315	1000	
APPD	RGG			DEVIATION	±0.1	±0.2	±0.3	±0.5	±0.8	
SCALE:- 1:1				TITLE:- OUTLINE DIMENSION FOR FOOT MOUNTED INDUCTION MOTOR						

SHRIRAM COATINGS

L-186,M.I.D.C. AREA AHMEDNAGAR-414 111.

Email- info@shriramcoatings.com

DRG NO. SC 722 R0